



EtherCAT[®]
Conformance tested
CS3E

Closed Loop Stepper Drive

Passed the conformance testing of ETG



Leadshine Technology Co., Ltd.

Website: www.leadshine.com

Service:

Tel: 86-755-2641-8774 (for Asia, Australia, Africa region)

86-755-8654-2465 (for Europe region)

86-755-2665-5136 (for America region)

86-755-2641-0546

Email: tech@leadshine.com

Sales Hot Line:

Tel: 86-755-2641-7674 (for Asia, Australia, Africa region)

86-755-2640-9254 (for Europe region)

86-755-2641-7617 (for America region)

Email: sales@leadshine.com

- ▶ Support CoE control and CiA 402 protocol
- ▶ Maximum communication rate of 100 Mbps
- ▶ Simplicity & High reliability
- ▶ No loss of step & Excellent performance
- ▶ 40% lower cost than EtherCAT servo

CS3E Series

These newly released CS3E series drives support CANopen over EtherCAT (CoE) control and CiA 402 operating modes including Profile Position (PP), Profile Velocity (PV), Homing(HM), Cyclic Synchronous Position (CSP). The products can be matched with most of EtherCAT controller/PLC such as Beckhoff, Trio, Omron, etc. The CS3E series has excellent performance including enhanced reliability, no loss of step, super-low stepper noise, anti-resonance, low-speed ripple smoothing and remains 40% less cost than EtherCAT servo at least. The CS3E can power 2-phase NEMA11, 14, 17, 23, 24 and 34 stepper motors with incremental encoders in many industrial applications such as CNC, medical, electronics, packaging...



CS3E Series Advantages

20 years' continuous improvement of step and servo controls.

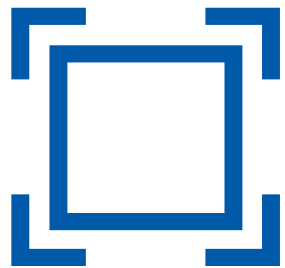

- High Reliability:**
 Successfully passed the conformance testing of the ETG, adopt LED display to show slave ID, velocity, error code...
- Enhanced Communication Rate:**
 Maximum rate of 100Mbps to ensure real-time control in automation environments.
- Excellent Performance:**
 No loss of step, make real-time position error correction, no need torque reservation, lower noise and heating, low-speed ripple smoothing, etc.

Customer Benefits

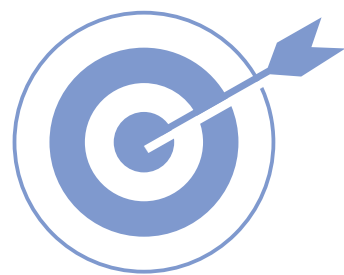

- Significantly reduced equipment cost:**
 At least lower 40% cost to replace EtherCAT servo when the required speed of applications under 2000 RPM.
- Significantly reduced potential cost:**
 Lower labor cost, lower cable cost and maintenance cost.
- Real-time data transfer:**
 Online monitoring of the status of motor and drive.

CS3E Series

EtherCAT System Connection Topology



Contents

1. CS3E Series Overview
2. CS3E Series Drives
3. Matching Closed Loop Stepper Motor
4. Cables and Power Supplies
5. Ordering Information

01 CS3E Series Overview

1.1 Features

1 Closed Position Loop to Eliminate Step Loss

Adopted closed loop step system to make real-time position error correction, can eliminate potential loss of step.

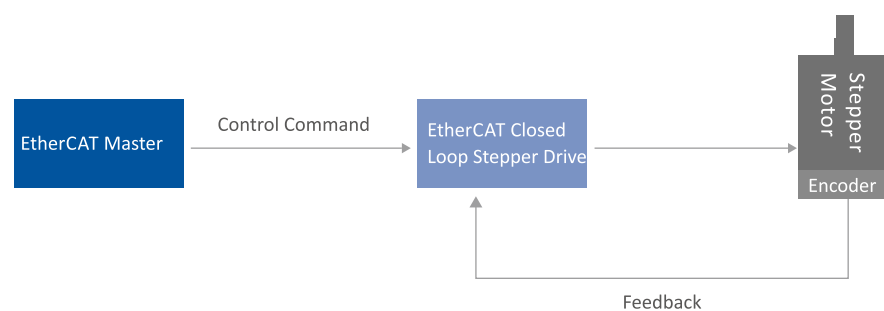

2 No Torque Reservation, Quicker Response and Enhanced Efficiency

Adopted EtherCAT technology and advanced control algorithm, with 30% better high speed performance than open loop stepper, can be used in applications with max speed at 2000RPM.

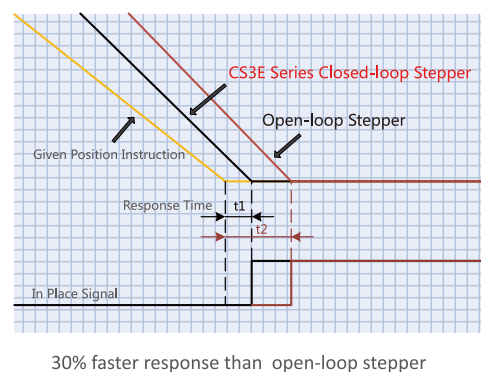
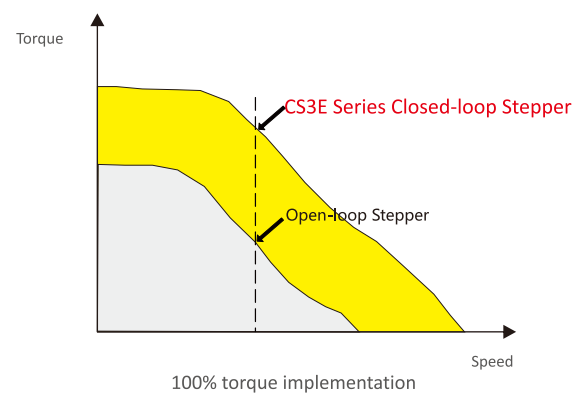

3 Smooth Motion and Extra Low Motor Noise

Adopted variable current control technology to reduce low speed vibration and noise.

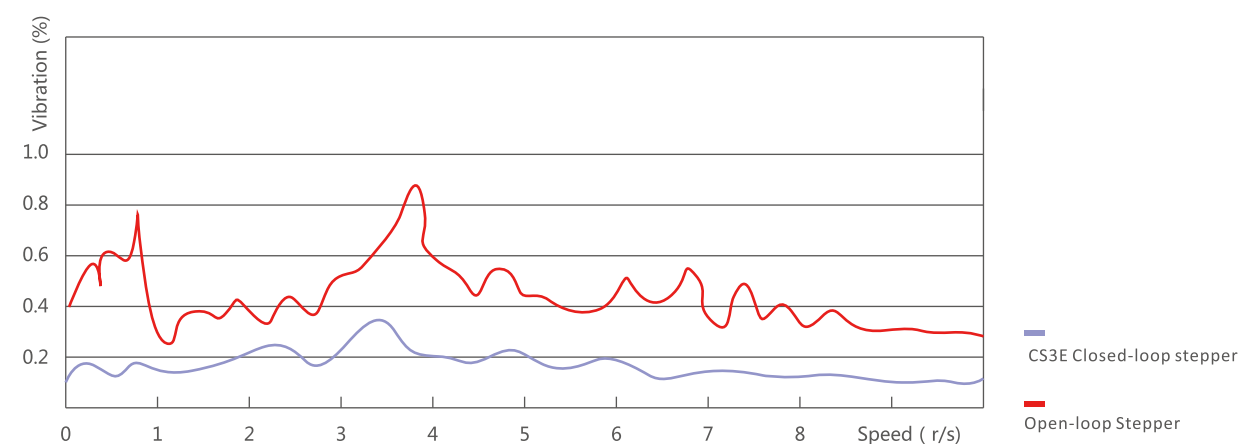

4 Reduced Motor Heating for Longer Motor Life Time

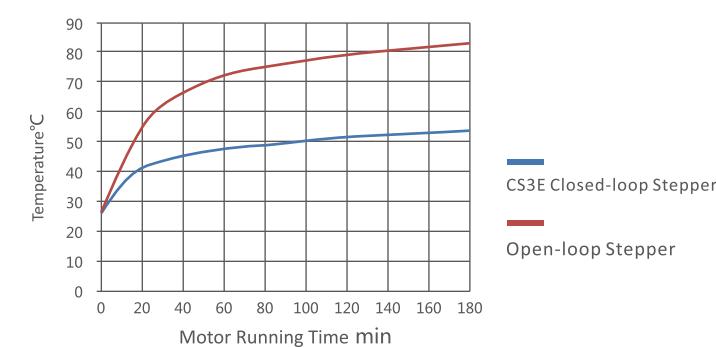
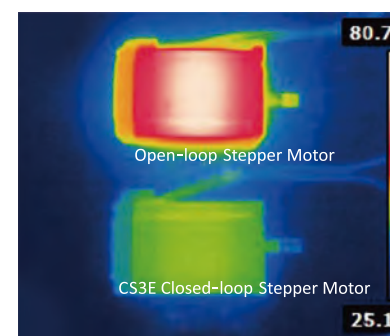

5 No Tuning and Easy to Upgrade Open Loop Stepper



No Tuning



Upgrade open-loop stepper

1.2 Typical Applications

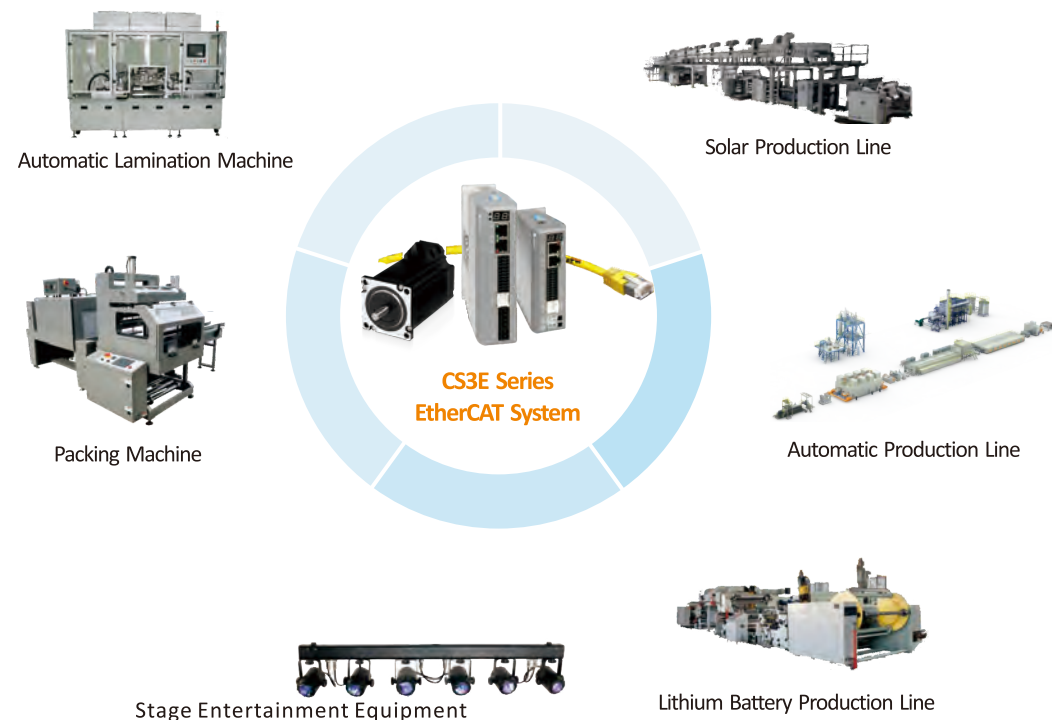

1.3 Typical Configuration

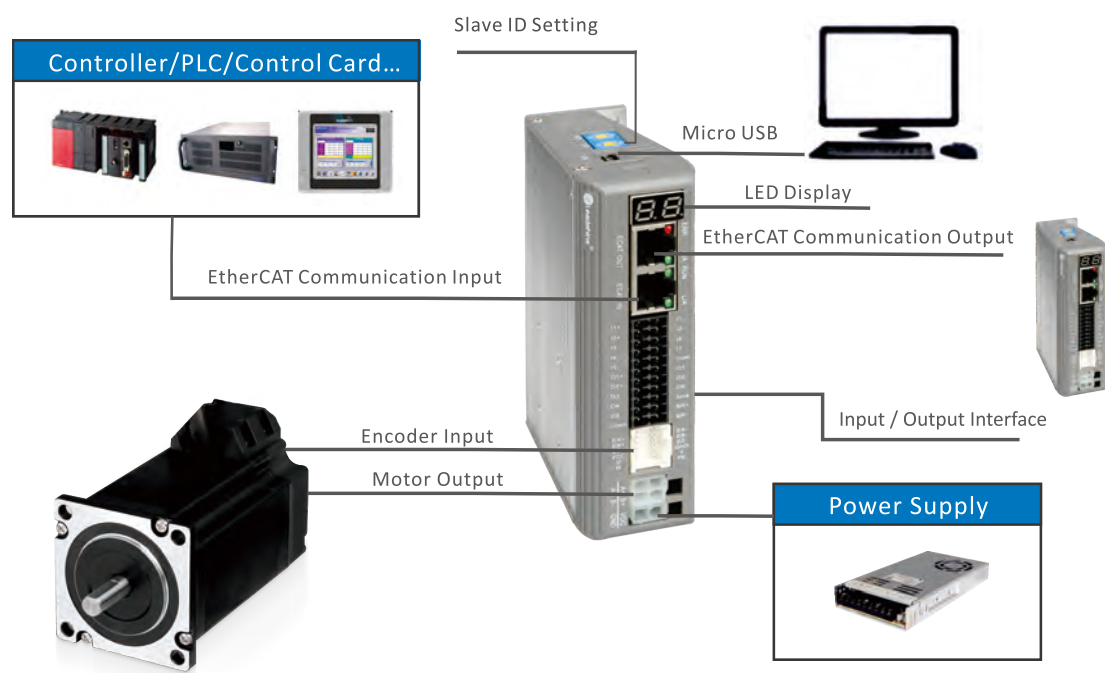

02 CS3E Series Drives





2.1 Part Number

CS3 - D 50 7

① ② ③ ④ ⑤ ⑥ ⑦

- ① Series Name:
CS3: CS3 Series
- ② Communication Modes:
E: EtherCAT
- ③ Product Type:
D: Drive
- ④ DC or AC Power Input:
Blank: DC Input
A: AC or DC Input Optional
- ⑤ Operating Voltage:
50: Max 50V
100: Max 100V
- ⑥ Max Output Current:
7: 7.0A
- ⑦ Customized Model

2.2 Electrical Specifications

EtherCAT Network Closed Loop Stepper Drives				
Models				
	CS3E-D503	CS3E-D507	CS3E-D728*	CS3E-D1008
Operating Voltage	20-50VDC	20-50VDC	20-72VDC	20-80VAC or 30-110 VDC
Output Current	0.3-2.5A(RMS 1.8A)	1.0-7.0A(RMS 5A)	2.1-8.0A(RMS 6A)	3.2-8.2A(RMS 6A)
Matched Motor	NEMA 11,14,17	NEMA 23,24	NEMA 23,24,34	NEMA 34

Note: (*) means it's coming soon, contact Leadshine for the latest developments.

2.3 EtherCAT Specifications

EtherCAT Network Closed Loop Stepper Drives	
Physical Layer	100BASE-TX
Communication Connector	RJ45 × 2 (ECATIN, ECATOUT)
Topology	Field bus
Baud Rate	2 × 100 Mbps (full-duplex channel)
Frame Data Length	1484 bytes (Max)
Synchronization Manger	SM0: email received (from master station to slave station) SM1: email sent (from slave station to master station) SM2: process data output (from master station to slave station) SM3: process data input (from slave station to master station)
FMMU	FMMU0 FMMU1 FMMU2
Synchronization Mode	DC Synchronization (SYNC0) Free Run
Communication Event	SDO, PDO, EMCY
LED indicator	L/A IN (Link/Activity IN) × 1 L/A OUT (Link/Activity OUT) × 1 RUN × 1 ERR × 1
Application Layer	IEC61800-7 CIA402 Drive Profile
Operation Modes	CSP, PV, PP, HM
Cycle Time	500us, 750us, 1ms, 2ms, 3ms, 4ms, 5ms

2.4 Main Interface Connectors

1 Encoder Input Connector

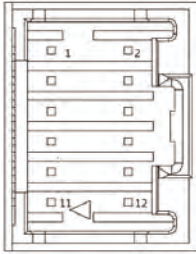
Name	Picture	PIN	Signal	Description
CN3		1	EA+	Encoder signal of phase A+
		2	EA-	Encoder signal of phase A-
		3	EB+	Encoder signal of phase B+
		4	EB-	Encoder signal of phase B-
		5	EZ+	Encoder signal of phase Z+
		6	EZ-	Encoder signal of phase Z-
		7	Vcc	Encoder +5V voltage
		8	GND	Encoder ground
		9, 10 ,11	NC	Reserved
		12	PE	Shield Earth

2 EtherCAT Communication Connector

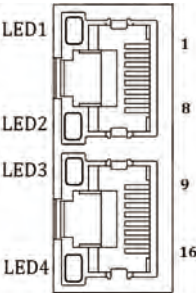
Name	Picture	PIN	Signal	Description
CN5		1, 9	E_TX+	EtherCAT TxD+
		2, 10	E_TX-	EtherCAT TxD-
		3, 11	E_RX+	EtherCAT RxD+
		4, 12	/	/
		5, 13	/	/
		6, 14	E_RX-	EtherCAT RxD-
		7, 15	/	/
		8, 16	/	/
		Cover	PE	Shield Earth

3 Slave ID Setting Switch

The Slave ID can be set by rotary switches of MSD and LSD. For example, if the MSD is set to "A" and LSD is set to "8", the slave ID is 168 (decimal)



4 I/O Signals Connector

Name	Picture	PIN	Signal	I/O	Description
CN4		1	I1+	I	Configurable Differential Digital Input I1, 3.3V - 5V, 500KHz, Touch Probe 1 (default)
		2	I1-	I	
		3	I2+	I	Configurable Differential Digital Input I2, 3.3V - 5V, 500KHz, Touch Probe 2 (default)
		4	I2-	I	
		5	I3	I	Configurable Single-ended Digital Inputs I3-I7, 12V - 24V, 10KHz, I3 is Origin Signal, I4 is Positive Limit, I5 is Negative Limit, I6 and I7 are GPIO. Compatible with common-cathode and common-anode
		6	I6	I	
		7	I4	I	
		8	I7	I	
		9	I5	I	
		10	COM1	I	
		11	O1+	O	
		12	O1-	O	
		13	O2+	O	Configurable Differential Digital Output O2, Max. 30V/100mA. In Position (default).
		14	O2-	O	
		15	O3	O	Configurable Single-ended Digital Outputs O3, O4, O6, Max. 30V/100mA, GPIO
		16	O6	O	
		17	O4	O	
		18	24VB	O	
		19	O5	O	Configurable Single-ended Digital Output O5, Max. 30V/100mA, GPIO
		20	BR+	O	Brake+ signal, Max. 24V/500mA, connect with brake coil
		21	COMO	O	Common-cathode for single-ended output
		22	BR-	O	Brake- signal, Max. 24V/500mA, connect with brake coil

2.5 Typical Connection

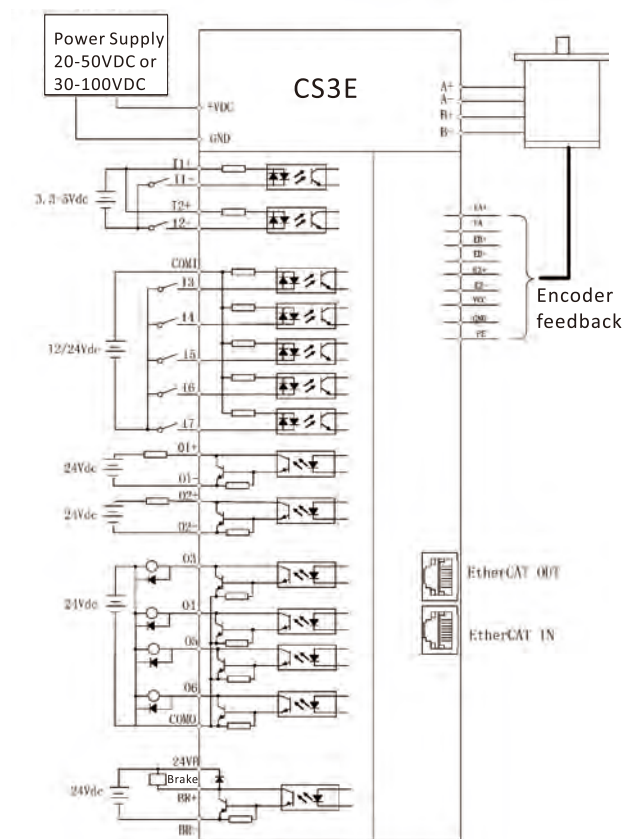

Note: I3-I7 digital input signals are compatible with common-cathode and common-anode.

2.6 Mechanical Specifications

Unit: mm 1inch=25.4mm

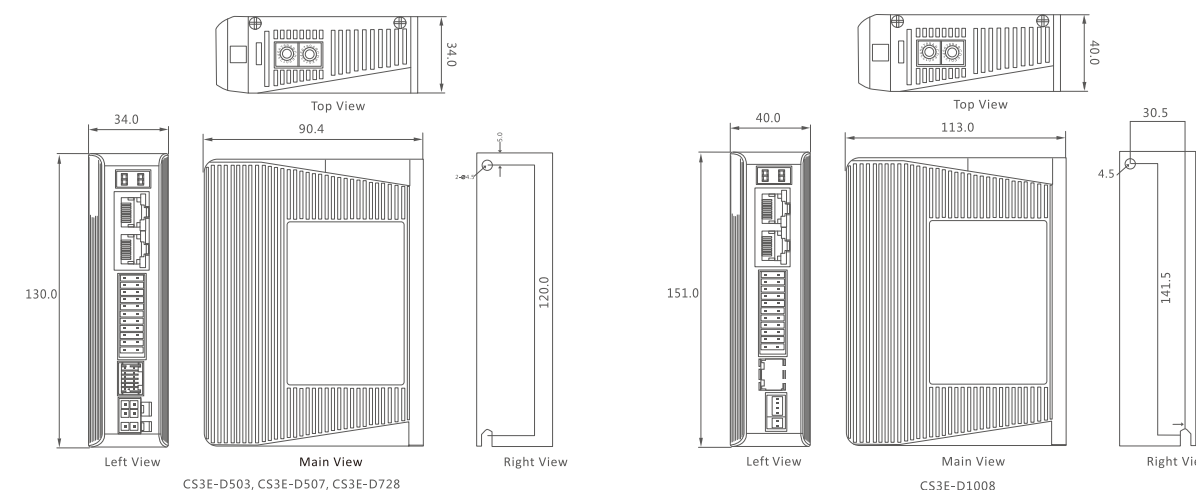

03 CS Series Motors

3.1 Part Number



- ① Motor Series
CS-M series closed-loop stepper motor
- ② Motor Phase
2: 2 phase motor
- ③ Motor Frame Size
17: NEMA 17 motor
23: NEMA 23 motor
34: NEMA 34 motor
- ④ Holding Torque
85: 8.5 N.m
- ⑤ Standard customized sepcification
B: Brake
WP: Waterproof
- ⑥ Customized
-S: Inch diameter
-L: Large NEMA23 motor
E2: 2500 line encoder

3.2 Models

Motor Size	Motor Model	Holding Torque (Nm)	Length (mm)		
			Standard	Brake	Waterproof
NEMA08	CS-M208003	0.024	53		
NEMA11	CS-M211013	0.13	63		
NEMA14	CS-M214015	0.15	46		
NEMA17	CS-M21702	0.2	56		
	CS-M21704	0.4	63		
	CS-M21706	0.6	70		
	CS-M21708	0.8	83		
NEMA23	CS-M22306	0.6	60		
	CS-M22313	1.3	75	109	94
	CS-M22323	2.3	95	131	115
	CS-M22326	2.6	103		
	CS-M22321-L	2.1	86		
	CS-M22331-L	3.1	105		
NEMA24	CS-M22422	2.2	89	129	113
	CS-M22430	3.0	107	143	130
NEMA34	CS-M23435	3.5	95		
	CS-M23445	4.5	109	134	115
	CS-M23480	8.0	127	152	133
	CS-M23485	8.5	147	172	153
	CS-M234120	12	158	183	164

Note: Contact Leadshine for planetary gearbox, NEMA17 motor with brake, motor with Z signal, etc.

3.3 Motor Specifications

1 Standard Motor Model

Standard NEMA17

Model	Length (mm)	Holding torque (N·m)	Rated current (A)	Inertia (Kg·cm ²)
CS-M21702	56	0.2	1.5	0.023
CS-M21704	63	0.4	1.5	0.045
CS-M21706	70	0.6	2.5	0.077
CS-M21708	83	0.8	2.5	0.11

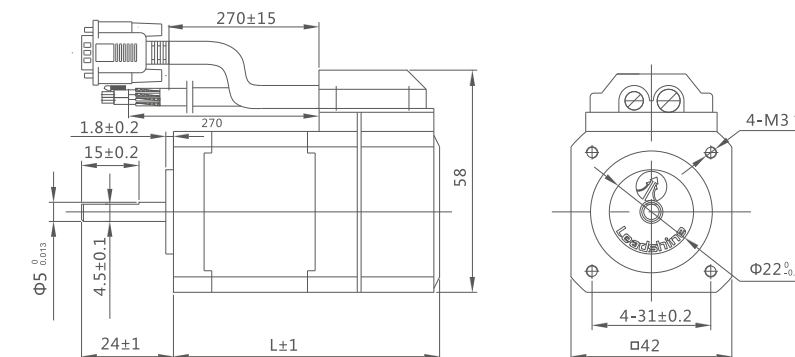

Standard NEMA23

Model	Length (mm)	Holding torque (N·m)	Rated current (A)	Inertia (Kg·cm ²)
CS-M22306	60	0.6	3.0	0.131
CS-M22313	75	1.3	4.0	0.3
CS-M22323	95	2.3	5.0	0.48
CS-M22326	103	2.6	5.0	0.7

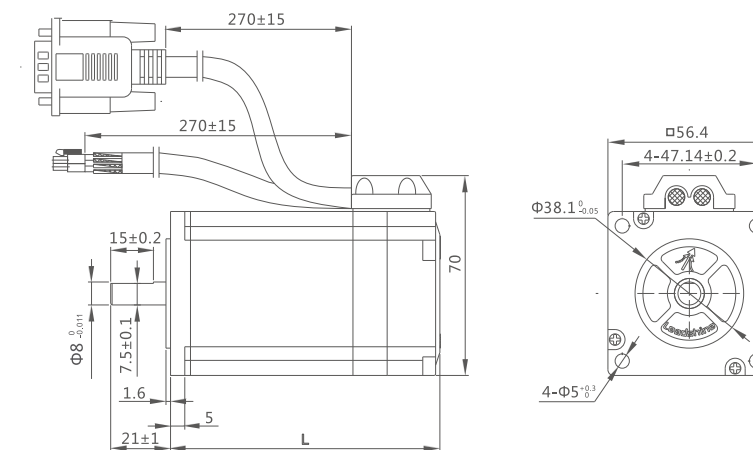

Note: CS-M22323 and CS-M22326 have models with shaft diameter 6.35mm.

■ Standard NEMA23 with Large Body

Model	Length (mm)	Holding torque (N·m)	Rated current (A)	Inertia (Kg·cm ²)
CS-M22321-L	86	2.1	5.0	0.49
CS-M22331-L	105	3.1	5.0	0.69

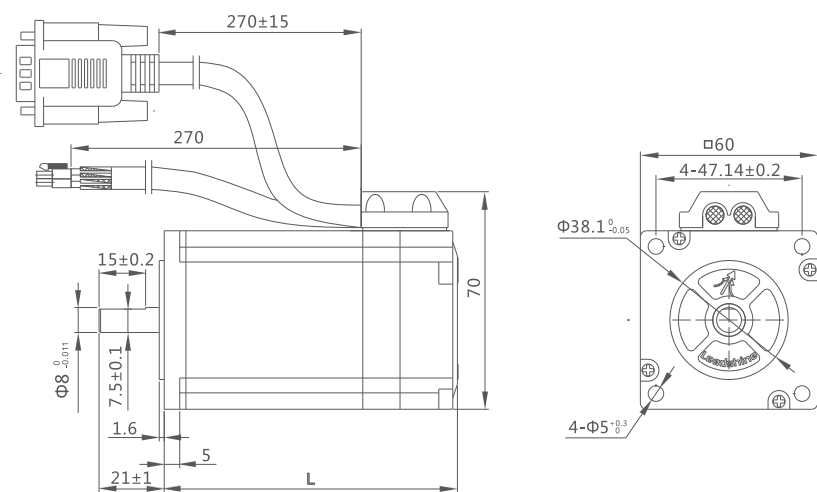

■ Standard NEMA24

Model	Length (mm)	Holding torque (N·m)	Rated current (A)	Inertia (Kg·cm ²)
CS-M22422	86	2.2	5.0	0.49
CS-M22430	103	3.0	5.0	0.69

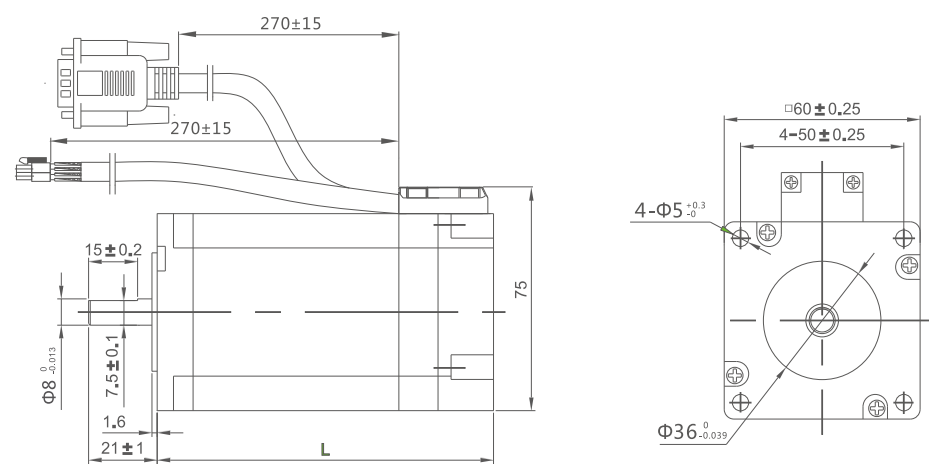

■ Standard NEMA34

Model	Length (mm)	Holding torque (N·m)	Rated current (A)	Inertia (Kg·cm ²)
CS-M23435	95	3.5	4.0	1.0
CS-M23445	109	4.5	6.0	1.95
CS-M23480	127	8.0	6.0	2.5
CS-M23485	147	8.5	6.0	2.8
CS-M234120	158	12.0	6.0	3.0

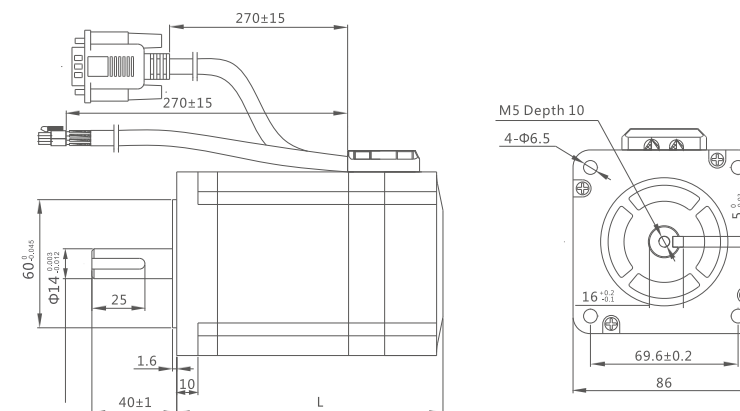

2 Motor with Brake

■ NEMA23 with Brake

Model	Length (mm)	Holding torque (N·m)	Rated current (A)	Inertia (Kg·cm ²)
CS-M22313B	114	1.3	4.0	0.28
CS-M22323B	134	2.3	5.0	0.48

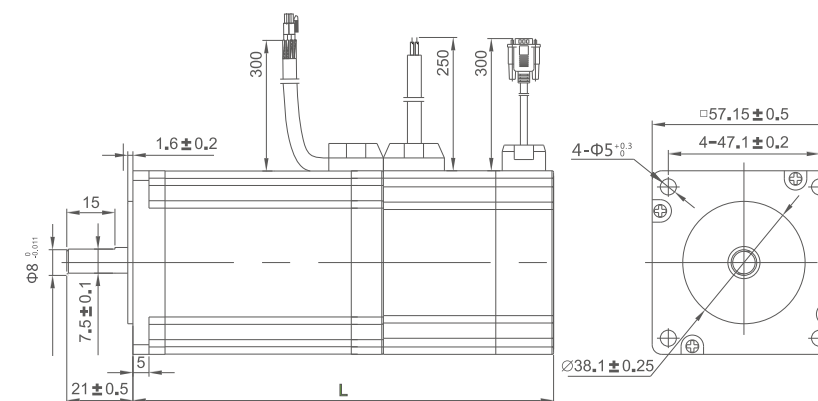

Note: Contact Leadshine for NEMA17 motor with brake.

■ NEMA24 with Brake

Model	Length (mm)	Holding torque (N·m)	Rated current (A)	Inertia (Kg·cm ²)
CS-M22422B	123	2.2	5.0	0.49
CS-M22430B	143	3.0	5.0	0.69

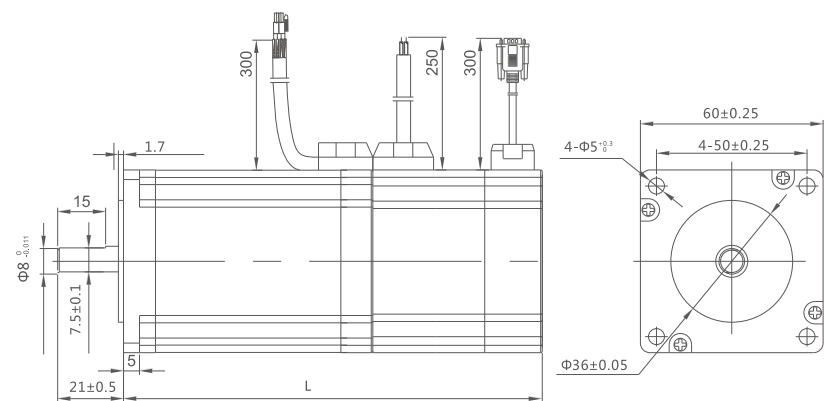

■ NEMA34 with Brake

Model	Length (mm)	Holding torque (N·m)	Rated current (A)	Inertia (Kg·cm ²)
CS-M23445B	135	4.5	6.0	1.95
CS-M23485B	173	8.5	6.0	2.8
CS-M234120B	184	12	6.0	3.0

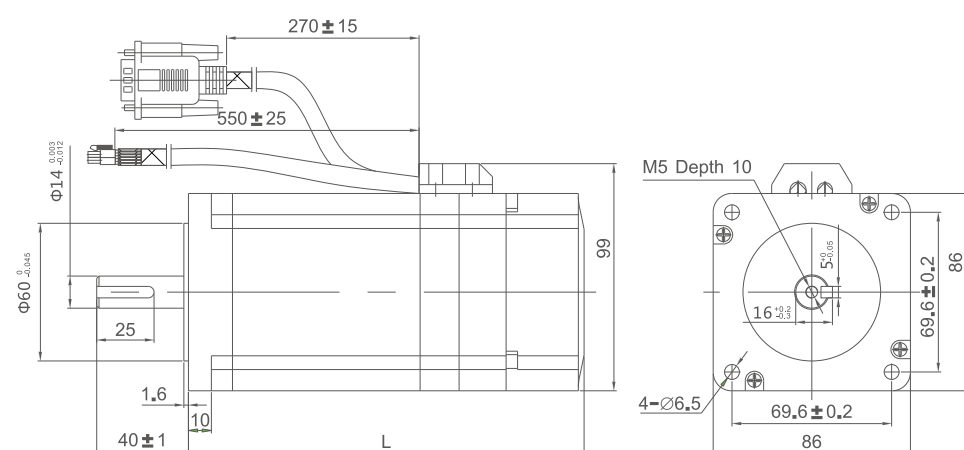

3 Motor with Waterproof

■ NEMA23 with Waterproof

Model	Length (mm)	Holding torque (N·m)	Rated current (A)	Inertia (Kg·cm ²)
CS-M22313WP	94	1.3	4.0	0.28
CS-M22323WP	115	2.3	5.0	0.48

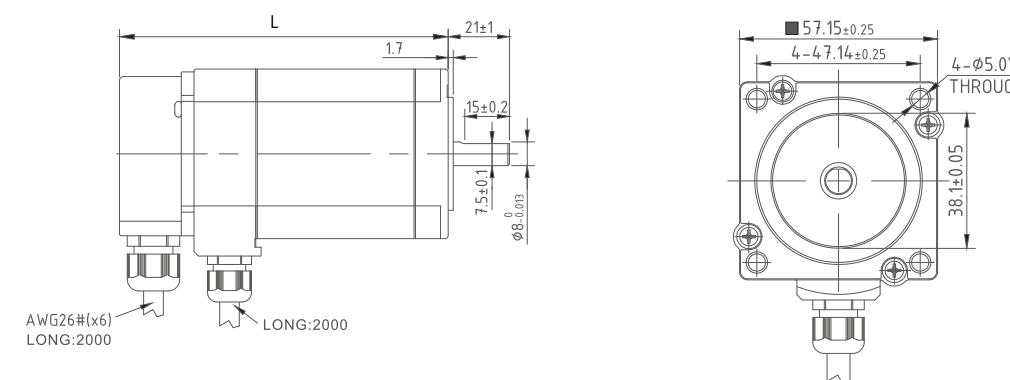

■ NEMA24 with Waterproof

Model	Length (mm)	Holding torque (N·m)	Rated current (A)	Inertia (Kg·cm ²)
CS-M22422WP	100	2.2	5.0	0.49
CS-M22430WP	130	3.0	5.0	0.69

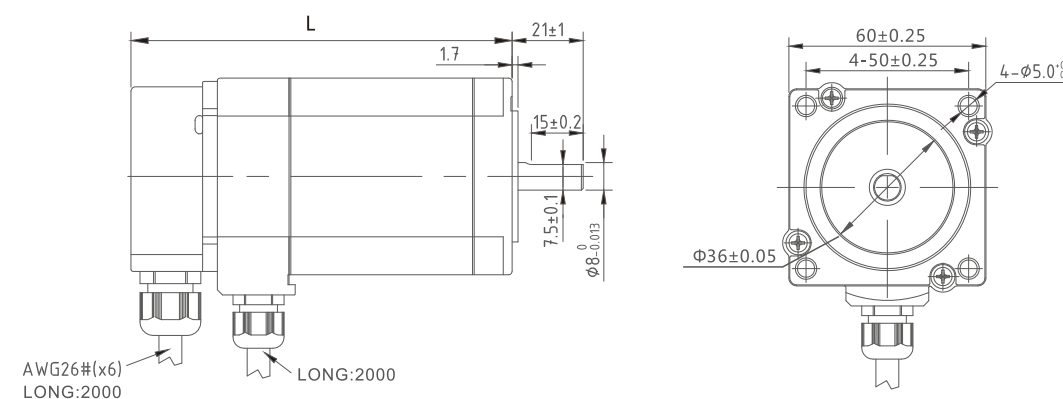

NEMA34 with Waterproof

Model	Length (mm)	Holding torque (N·m)	Rated current (A)	Inertia (Kg·cm ²)
CS-M23445WP	115	4.5	6.0	1.95
CS-M23480WP	133	8.0	6.0	2.5
CS-M23485WP	153	8.5	6.0	2.8
CS-M234120WP	164	12	6.0	3.0

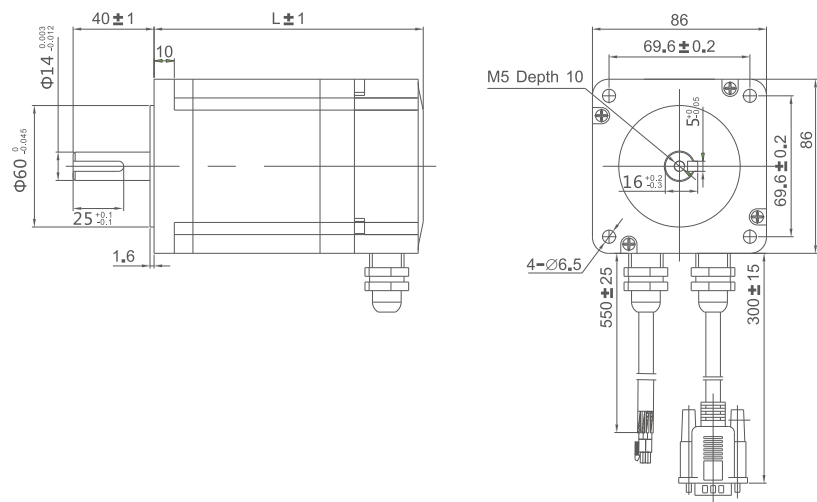

3 Motor Torque-Speed Curve

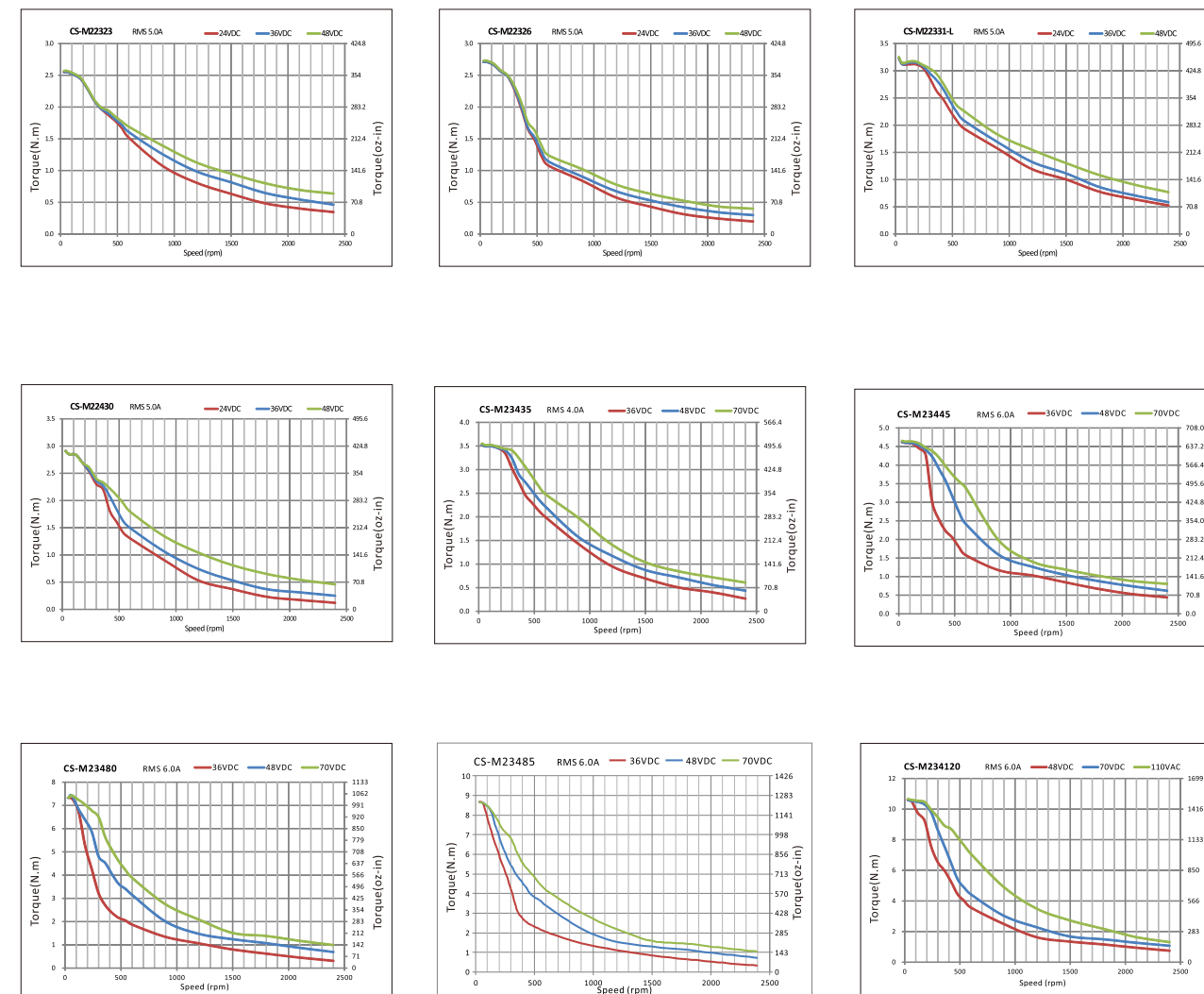
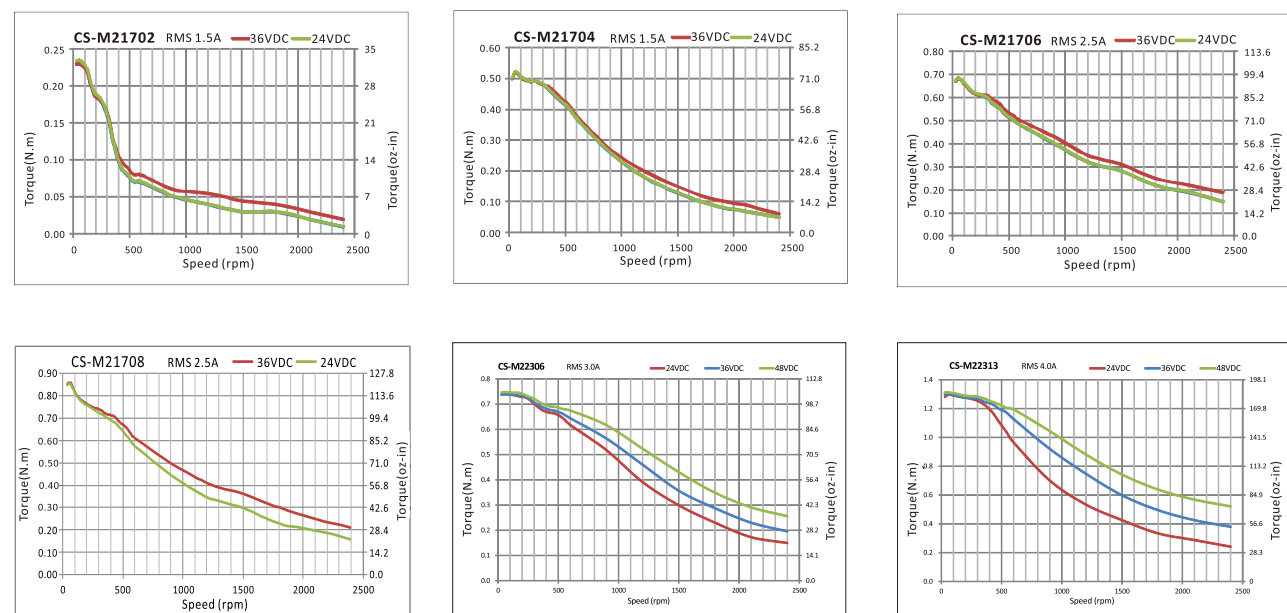

CS3E Series Overview

CS3E Series Drives

CS Series Motor

Cables and Power Supplies

Ordering Information

04 Cables and Power Supplies

4.1 Power Supplies

1 SPS Series Power Supplies

Features

- Specially Designed Power Supplies for Stepper and Servo Controls
- Compact Size, Light in Weight
- Wide Input Voltage Range, 220VAC ± 10% or 110 VAC ± 10%
- Over-current, Over-voltage, Low-voltage Protections
- Big Power with High Efficiency
- Easy to Use



Electrical Specifications

Model	Output Voltage (VDC)	Continuous Current (A)	Peak Current (A)	Input Voltage	Matching Drives	Dimensions	Weight(Kg)
SPS2410(V3.0)	24	10	30	220VAC± 10% or 110 VAC ± 10%	CS3E-D503/ CS3E-D507/ CS3E-D728	199*110*50mm	0.8
SPS3611(V3.0)	36	11	33			215*110*30mm	0.6
SPS488(V3.0)	48	8.3	24.9			215*110*30mm	0.6
SPS4810(V3.0)	48	10	30			215*110*50mm	0.8
SPS606(V3.0)	60	6.7	20.1		CS3E-D728/ CS3E-D1008	215*110*30mm	0.6

Mechanical Specifications

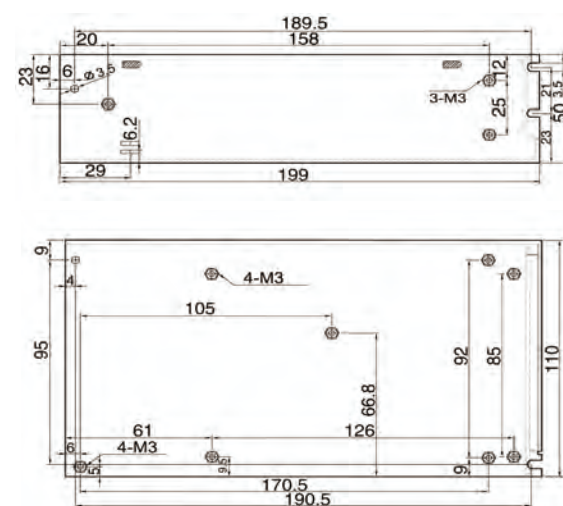

SPS2410(V3.0)

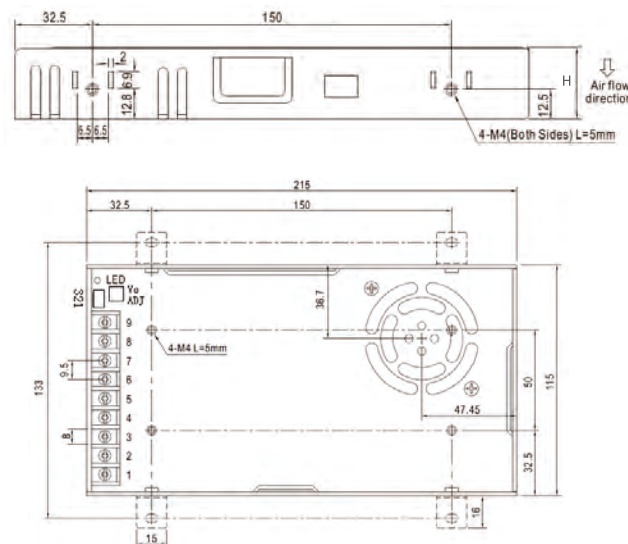

SPS3611(V3.0)/SPS488(V3.0)/SPS606(V3.0) H=30mm
SPS4810(V3.0) H=50mm

4.2 Cables

1 Motor Extension Cable

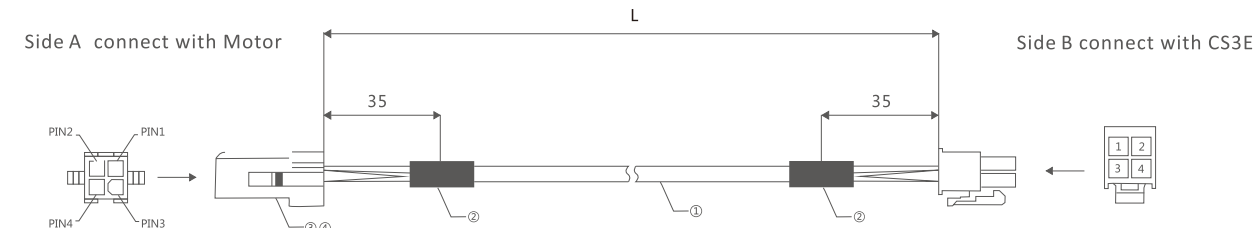

Side A PIN	1	2	3	4
Color	Green	Red	Black	Yellow
Signal	B-	A-	A+	B+
Side B PIN	Black	Red	White	Yellow

Model	Length L (mm)
CABLEM-RZ1M5	1500
CABLEM-RZ3M0	3000
CABLEM-RZ5M0	5000
CABLEM-RZ8M0	8000
CABLEM-RZ10M0	10000
CABLEM-RZ12M0	12000
CABLEM-RZ15M0	15000

2 Encoder Extension Cable

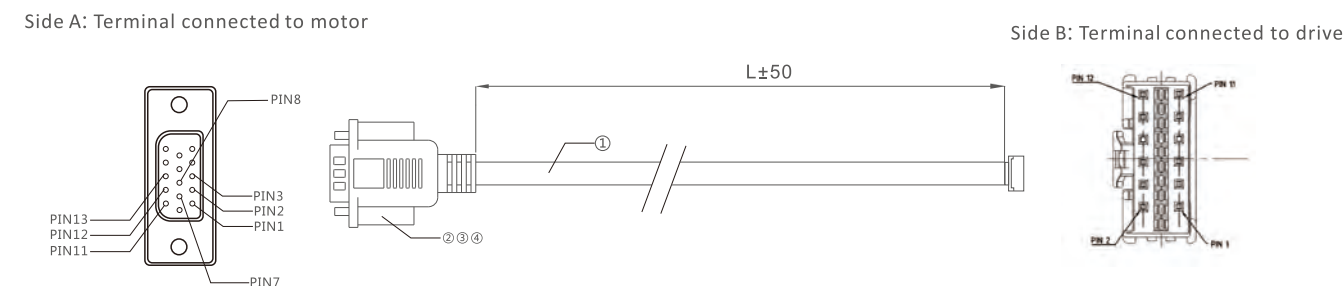

Side A PIN	1	2	3	7	8	11	12	13
Color	Black	Red	White	NC	NC	Yellow	Green	Blue
Signal	A+	VCC	GND	NC	NC	B+	B-	A-
Side B PIN	1	7	8	5	6	3	4	2

Model	Length L (mm)
CABLEM-BM1M5	1500
CABLEM-BM3M0	3000
CABLEM-BM5M0	5000
CABLEM-BM8M0	8000
CABLEM-BM10M0	10000
CABLEM-BM12M0	12000
CABLEM-BM15M0	15000

Note: For motor with Z signal, the model of encoder extension cable is CABLEM-BMxMxZ

3 CS3E Tuning Cable

Model	Length	Picture
CABLE-MUSB1M5	1500mm	

4 EtherCAT Communication Cable

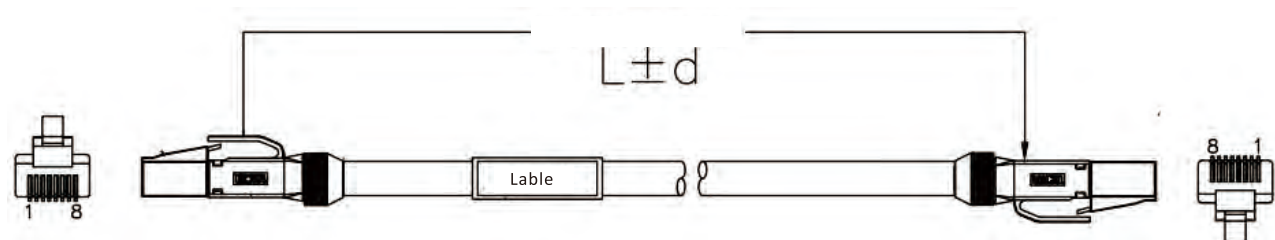

Model	Length (L)	Tolerance (d)
CABLE-TX0M1-BUS RoHS	100mm	±10mm
CABLE-TX0M2-BUS RoHS	200mm	±10mm
CABLE-TX0M3-BUS RoHS	300mm	±10mm
CABLE-TX0M5-BUS RoHS	400mm	±10mm
CABLE-TX1M0-BUS RoHS	1000mm	±10mm
CABLE-TX1M5-BUS RoHS	1500mm	±10mm
CABLE-TX2M0-BUS RoHS	2000mm	±10mm
CABLE-TX3M0-BUS RoHS	3000mm	±10mm
CABLE-TX5M0-BUS RoHS	5000mm	±10mm
CABLE-TX7M0-BUS RoHS	7000mm	±10mm
CABLE-TX10M0-BUS RoHS	10000mm	±10mm
CABLE-TX15M0-BUS RoHS	15000mm	±10mm
CABLE-TX20M0-BUS RoHS	20000mm	±10mm

05 Ordering Information

	CS3E-D503	CS3E-D507	CS3E-D728* / CS3E-D1008
EtherCAT Closed-loop Stepper Drives			
Closed-loop Stepper Motors	CS-M208003	CS-M22306	CS-M23435
	CS-M211013	CS-M22313	CS-M23445
	CS-M214015	CS-M22323	CS-M23480
	CS-M21702	CS-M22326	CS-M23485
	CS-M21704	CS-M22321-L	CS-M234120
	CS-M21706	CS-M22331-L	
	CS-M21708	CS-M22422	
		CS-M22430	
Accessories	CABLEM-RZ series motor extension cable (necessary)		
	CABLEM-BM series encoder extension cable (necessary)		
	CABLE-MUSB1M5 Tuning cable		
	CABLE-TX series EtherCAT communication cable		

Note: (*) means it's coming soon, contact Leadshine for the latest developments.